

ASPECTO MONTADO / ASSEMBLY ASPECT /
 ASPECTO LISTO

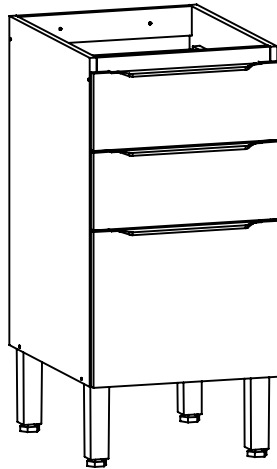

ASPECTO TRASEIRO / BOTTOM ASPECT /
 ASPECTO TRASERO

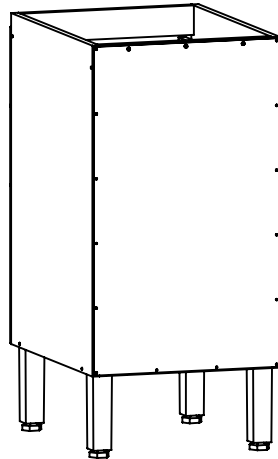

FERRAMENTAS NECESSÁRIAS P/ MONTAGEM.
 (NÃO SÃO FORNECIDAS)
 REQUIRED TOOLS FOR ASSEMBLY. (NOT PROVIDED)
 HERRAMIENTAS NECESSARIAS.
 (NO PROPORCIONADAS)



LISTA DE PEÇAS / LIST OF PIECE / LISTAJE DE PIEZAS

Nº	COD	NOME DA PEÇA / NAME OF THE PIECE / NOMBRE DE LA PIEZA	MEDIDA	QTDE	MAT. PRIMA
01	111975	ACESSÓRIO DE MONTAGEM / ASSEMBLY ACCESSORY / ACCESORIO DE MONTAJE	-	01	DIVERSOS
02	910897	CORREDIÇA (PAR) / SLIDING (EQUAL) / CORREDERA (PAR)	400MM	02	METAL
03	908640	PÉS / FEET / PATA	170MM	04	PLÁSTICO
04	111976.0675.0500	LATERAL DIREITA / RIGHT LATERAL / LATERAL DERECHA	675x500x15	01	MDP
05	111977.0675.0500	LATERAL ESQUERDA / LEFT LATERAL / LATERAL IZQUIERDA	675x500x15	01	MDP
06	102432.0370.0500	BASE / BASE / BASE	370x500x15	01	MDP
07	111713.0159.0395	FRENTE DE GAVETA / DRAWER FRONT / FRENTE DEL CAJÓN	159x395x15	02	MDP
08	111978.0320.0395	PORTA INFERIOR / LOWER DOOR / PUERTA INFERIOR	320x395x15	01	MDP
09	106953.0370.0060	SUPORTE FRONTAL / FRONT SUPPORT / APOYO FRONTAL	370x60x15	01	MDP
10	105071.0370.0060	SUPORTE TRASEIRO / BOTTOM SUPPORT / APOYO TRASERO	370x60x15	01	MDP
11	108425.0400.0100	LATERAL GAVETA DIREITA / RIGHT DRAWER SIDEBOARD / LATERAL CAJÓN DERECHA	400x100x15	02	MDP
12	108426.0400.0100	LATERAL GAVETA ESQUERDA / LEFT DRAWER SIDEBOARD / LATERAL CAJÓN IZQUIERDA	400x100x15	02	MDP
13	111286.0316.0078	CONTRA FUNDO GAVETA / DRAWER BOTTOM BOARD / CONTRA FONDO DEL CAJÓN	316x78x15	02	MDP
14	111288.0405.0326	FUNDO DE GAVETA / DRAWER BOTTOM / FONDO DEL CAJÓN	405x326x03	02	MADEFIBRA
15	102431.0670.0395	TRASEIRO / BOTTOM / TRASERO	670x395x03	01	MADEFIBRA

→ CÓDIGOS IDENTIFICADOS NO TOPO DA MAIORIA DAS PEÇAS DO PRODUTO.
 THESE CODES ARE IDENTIFIED ON THE SIDE OF MOST PARTS OF THE PRODUCT.
 CÓDIGO IMPRESO EN EL CANTO CRUDO DE LA MAYORIA DE LAS PIEZAS.

LISTA DE ACESSÓRIO / ACCESSORY LIST / LISTAJE DE ACCESORIO - 1X1

	A 12		F 02
911268 - PARAF. 3,5X12 CHATA CABEÇA 6,8		903563 - PARAF. 6,0X50	
	B 56		G 25
907532 - PARAF. 4,0X12 CABEÇA PANELA		904801 - PREGO 09X09	
	C 04		H 16
909192 - PARAF. 3,5X25 CABEÇA CHATA		902913 - CAVILHA 8X30	
	D 04		I 02
903557 - PARAF. 5,0X35 FLANGEADO		900053 - BUCHA 08	
	E 18		
903542 - PARAF. 3,5X40			

LISTA DE ACESSÓRIO / ACCESSORY LIST / LISTAJE DE ACCESORIO

	J 02		K 08		L 04		M 03
910610 - DOBRADIÇA BAIXA COM AMORTECEDOR		902900 - CANTONEIRA METÁLICA P/ VISTA		910914 - KIT C/ 2 TAPA FURO ADESIVO 13MM		911354 - PUXADOR 256MM ESP 15	

ESTRUTURA
STRUCTURE
ESTRUCTURA

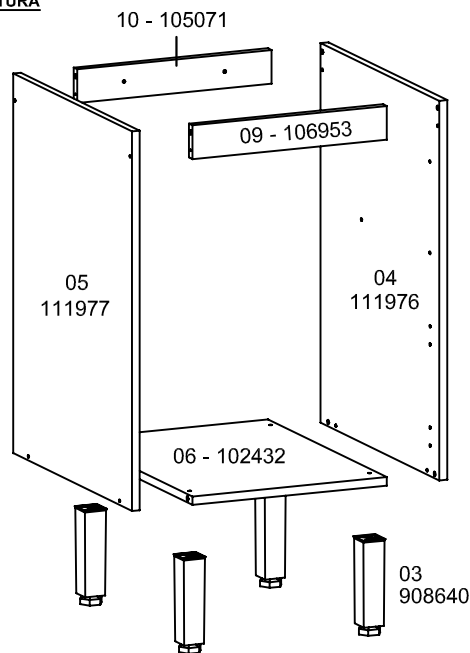

TRASEIRO
BOTTOM
TRASERO

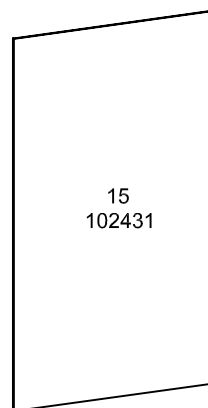

FRENTE
FRONT
FRENTE

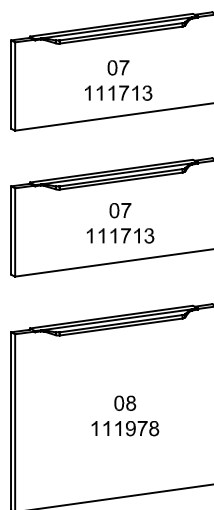

GAVETA
DRAWER
CAJÓN

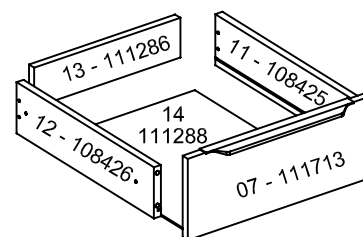

- PESSOAS NECESSÁRIAS P/ MONTAGEM.
 - REQUIRED PEOPLE FOR ASSEMBLY.
 - CANTIDAD DE PERSONAS NECESARIAS P/ ARMAR.



ATENÇÃO / ATTENTION / ATENCIÓN:

- A LIMPEZA DO MÓVEL DEVE SER EFETUADA SOMENTE COM PANO MACIO E MODERADAMENTE UMEDECIDO COM ÁGUA PURA OU SOLUÇÃO COM SABÃO NEUTRO.
- FOR CLEANING, USE ONLY A SOFT CLOTH MODERATELY MOISTENED WITH PURE WATER OR A SOLUTION WITH NEUTRAL SOAP.
- PARA LIMPIEZA DEL MUEBLE USAR PAÑO SUAVE Y MODERADAMENTE HUMEDECIDO CON AGUA PURA O SOLUCIÓN CON JABÓN NEUTRO.
- NÃO UTILIZE PRODUTOS QUÍMICOS OU ABRASIVOS, TAIS COMO: CERA, ÁLCOOL, DETERGENTES, TINNER.
- DO NOT USE CHEMICAL OR ABRASIVE PRODUCTS. FOR EXAMPLE: WAX, ALCOHOL, DETERGENT, THINNER.
- NO APLICAR PRODUCTOS QUÍMICOS O ABRASIVOS TAIS COMO: CERAS, ALCOOL, THINNER, DETERGENTE.
- AO SOLICITAR ASSISTÊNCIA TÉCNICA, INFORME O CÓDIGO DO PRODUTO, A COR E O CÓDIGO DA PEÇA CORRETAMENTE.
- WHEN REQUESTING TECHNICAL ASSISTENCE, INFORM THE PRODUCT CODE, THE COLOR AND THE PIECE CODE CORRECTLY.
- SI NECESITAR REPUESTOS, INFORMAR EL CÓDIGO DEL PRODUCTO, EL COLOR Y EL CÓDIGO DE LA PIEZA.

① MONTAGEM DAS GAVETAS.
 DRAWERS ASSEMBLY.
 MONTAJE DE LOS CAJONES.

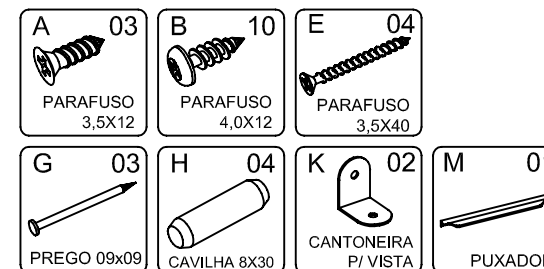
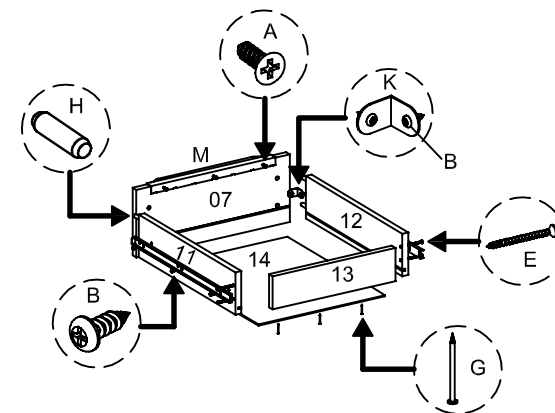



② MONTAGEM DA ESTRUTURA.
 STRUCTURE ASSEMBLY.
 MONTAJE DE LA ESTRUCTURA.

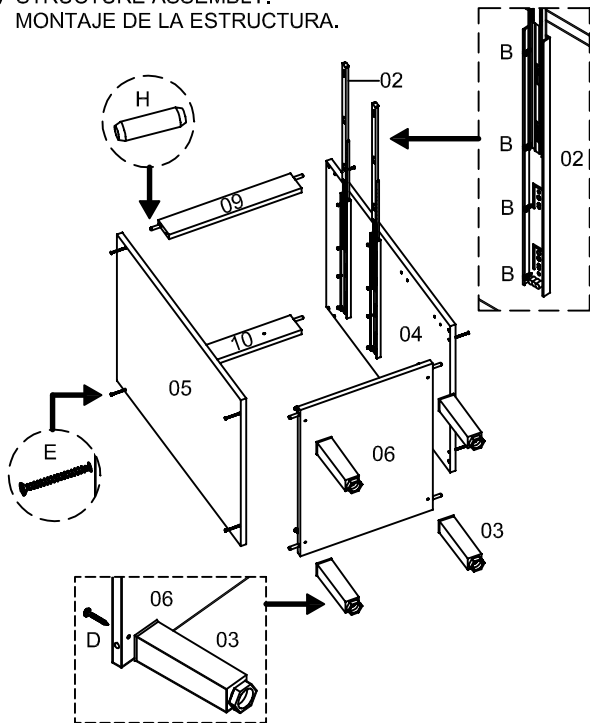
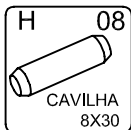
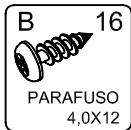

③ FIXAÇÃO DO TRASEIRO.
 BOTTOM ATTACHMENT.
 FIJACIÓN DEL TRASERO.

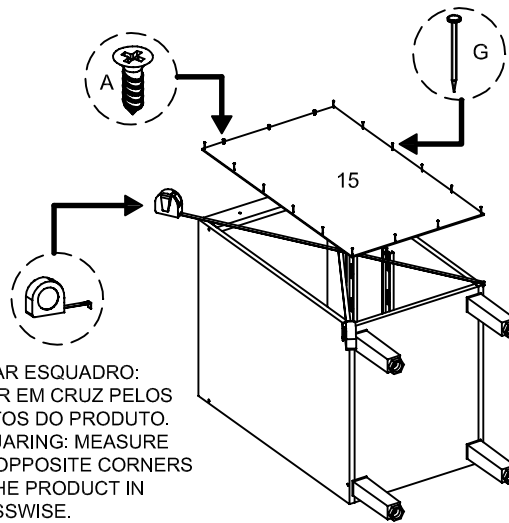

- TIRAR ESQUADRO:
 - MEDIR EM CRUZ PELOS
 CANTOS DO PRODUTO.
 - SQUARING: MEASURE
 THE OPPOSITE CORNERS
 OF THE PRODUCT IN
 CROSSWISE.
 - ESCUADRAR: TOMAR LA
 MEDIDA ENTRE LAS
 EXTREMIDADES INVERSAS
 DEL PRODUCTO.

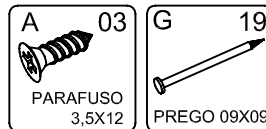

④ COLOCAÇÃO DAS GAVETAS.
 DRAWERS PLACEMENT.
 COLOCACIÓN DE LOS CAJONES.

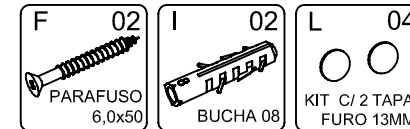
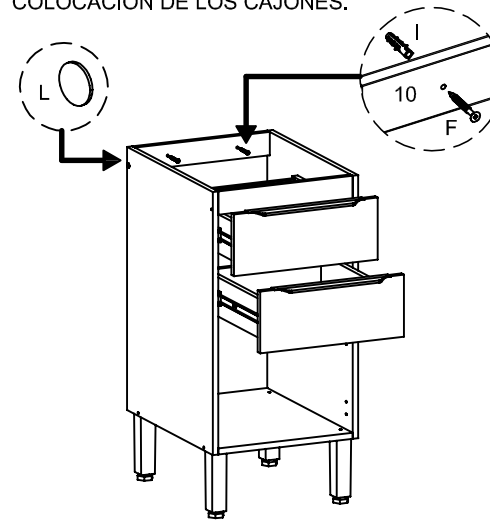

⑤ COLOCAÇÃO DA PORTA.
 DOOR PLACEMENT.
 COLOCACIÓN DE LA PUERTA

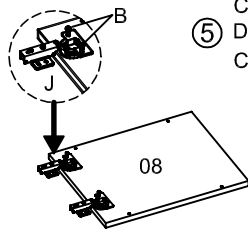

- INFORMAÇÃO AO MONTADOR:
 USAR PARAFUSADEIRA NO
 TORQUE BAIXO!
 - INFORMATION TO THE
 ASSEMBLER: USE THE CORDLESS
 DRILL AT LOW TORQUE.
 - INFORMACIÓN AL ARMADOR:
 UTILIZAR ATORNILLADOR EN
 TORQUE FLACO.

A ABERTURA DA PORTA PODE SER
 À DIREITA OU À ESQUERDA.
 THE DOOR OPENING CAN BE TO THE
 RIGHT OR TO THE LEFT.
 LA ABERTURA DE LA PUERTA PUEDE
 SER A LA DERECHA O IZQUIERDA.

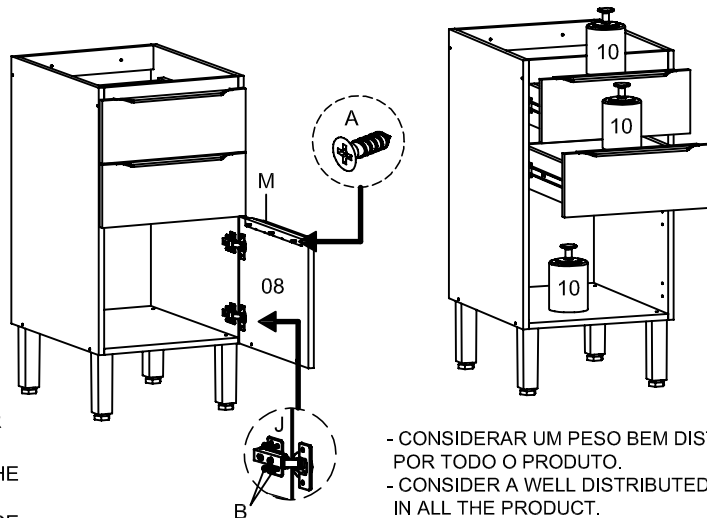

* LIMITE DE PESO MÁXIMO SUPORTADO (KG).
 * WEIGHT CAPACITY (KG).
 * CAPACIDAD DE PESO (KG).

- PARA UNIÃO DOS MÓDULOS, FAZER USO DO PARAF. 3,5X25 (C).
 - FOR THE MODULES UNION, USE SCREW 3,5X25 (C).
 - PARA LA UNIÓN DE LOS MÓDULOS, USE EL TORNILLO 3,5X25 (C).

- CONSIDERAR UM PESO BEM DISTRIBUÍDO
 POR TODO O PRODUTO.
 - CONSIDER A WELL DISTRIBUTED WEIGHT
 IN ALL THE PRODUCT.
 - CONSIDERAR UN PESO BIEN DISTRIBUIDO
 EN TODO EL PRODUCTO.

